

# Solid Wall Die Heads

Rollepaal's years of experience in extrusion has resulted in products that are based on a sound theoretical approach combined with broad practical experience. The Rollepaal Solid Wall Die Head (RSD) is the tried and tested heart of a solid wall PVC pipe extrusion line.



**Rollepaal**

Pipe Extrusion Technology

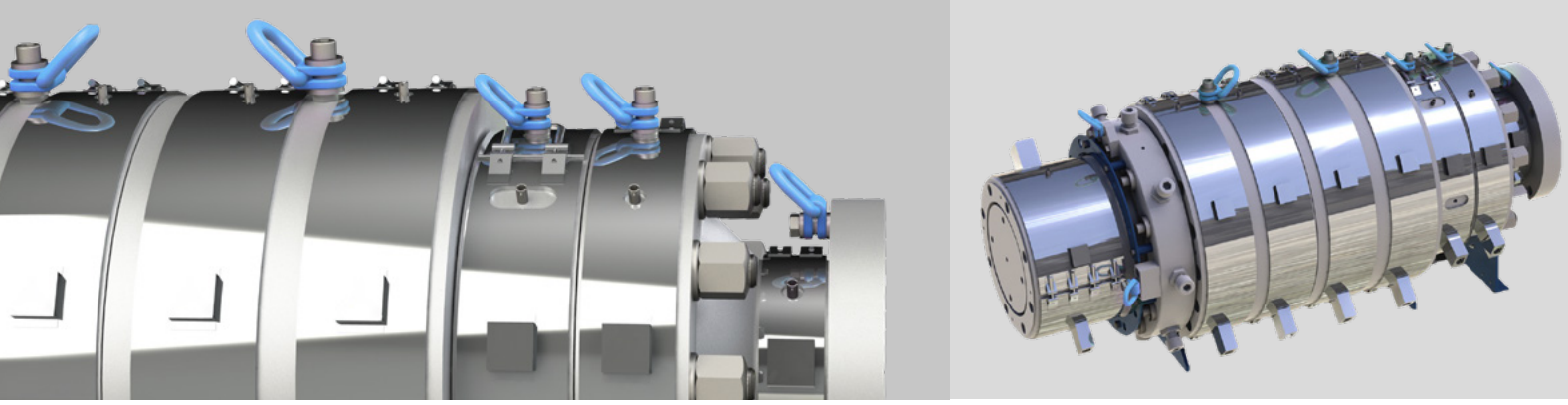

# Solid Wall Die Heads

RSD die heads have been computer designed using a calculation program based on a 3D viscoelastic model for plastics. The program calculates the optimum flow lines for compression cones that otherwise would not be feasible for reliable use in production. Rollepaal spider dies reach the highest efficiency possible in terms of raw material

consumption. The RSD die heads have also been designed to be robust, easy to assemble and dismantle, and are maintenance friendly. The flow lines have been optimised for reliable and reproducible production and allow high output and easy to run formulations. As the compression is high, the pipes are smooth without weak spider lines.

## Features and benefits

- ▶ Quick tool change - less time changing wall thickness and diameter, available for RSD 2, 4, 6 and 8
- ▶ Thermal centring - temperature control zones at the die head for rapid wall thickness adjustments
- ▶ Modular design - less tooling required for a larger range of pipe diameters
- ▶ A smooth pipe and low overweight at high output
- ▶ Designed for runners and variety products
- ▶ Minimum tooling for maximum pipe range
- ▶ Perfect spider line welding thanks to double compression
- ▶ Low inventory allows for lower dry blend stabilisation
- ▶ Smart centring - reduce centring time after diameter change (RSD12 and larger)

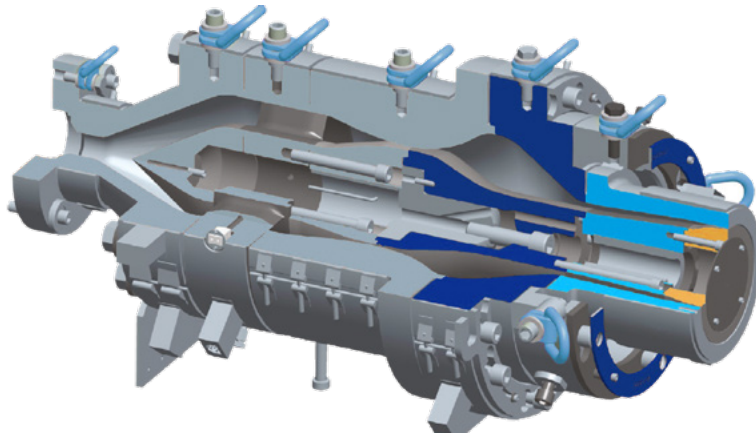

Wall thickness	3-6 minutes*	Orange	Light Blue	Dark Blue
Diameter change	6-12 minutes*	Orange	Light Blue	Dark Blue
Range change	12-20 minutes*	Orange	Light Blue	Dark Blue

\* Changeover times depend on diameter range

## Product range

Type	∅ = inch	10	20	40	2	50	63	90	4	110	160	6	200	8	250	10	315	12	400	16	500	20	630	24	800	32	1000	40	1200	48	
RSD 2	∅ = mm	10	20	40	50	63	90	110	160	200	250	315	400	500	630	800	1000	1200													
RSD 4																															
RSD 6																															
RSD 8																															
RSD 12																															
RSD 16																															
RSD 20																															
RSD 24																															
RSD 30																															
RSD 48																															

Rollepaal accepts no liability for losses of any kind whatsoever that may arise from the use of this information. Rollepaal reserves the right to make technical changes without prior notice.



**Rollepaal**

Pipe Extrusion Technology

P.O. Box 21  
7700 AA Dedemsvaart  
The Netherlands  
Rollepaal 13  
7701 BR Dedemsvaart

Phone +31 (0)532 62 45 99  
info@rollepaal.com

www.rollepaal.com